

Using Bidirectional Programmable DC Power Supplies for Battery Testing

Introduction

In today's fast-paced world the need to create quicker, more mobile mechanical devices is steadily increasing. One primary method for doing this is to replace traditional gas powered or plugged-in devices with battery power. Batteries have become smaller and increasingly efficient as a result. In order to keep up with the rate of technology advancement, the equipment used to test advanced technology must also be advanced, flexible and responsive. For these reasons, the PSB bidirectional programmable DC power supply series by EA Elektro-Automatik is a perfect fit for advanced battery test. The PSB bidirectional supply can seamlessly switch between providing power to charge the battery and controlling the discharge of the battery. Specifying just the right equipment, the following will provide some basic guidance and considerations on how to build a robust battery test system to ensure the safety and proper functioning of all test equipment and batteries under test.

Critical Equipment

The fact remains that it is possible to test a battery with simply a DC power supply and some cables, but the risk of damage to you, the power supply or the battery will be quite high. The smart and responsible way to test a battery with a DC power supply is to have the proper monitoring and safety equipment to greatly reduce the risk of problems. The proper equipment for creating a fully functional battery test rig can be broken down to 3 basic categories: control, monitoring and safety. Basically, you need to have a plan, a way to verify everything is working properly and a backup if there is unexpected behavior.

Control

Just like the category implies, we must first be able to have complete control over the battery tests that will be performed. In order to do that we will have to control the following variables of charge/discharge current, voltage and power. The complete solution for accomplishing this is a programmable DC power supply paired with a programmable DC load. Even more ideal is having both of those functions in one unit like the Elektro-Automatik PSB series. The PSB is bidirectional, meaning it can source (provide) or sink (absorb) current and regenerate that current to the local power grid with up to 95% efficiency. That's right, the electronic load function is regenerative, making this a very green solution on top of minimizing test equipment space and investment. The PSB has the same controls and features of a traditional, programmable DC power supply or electronic DC load to easily control the charge/discharge voltage, current and power going to and from the battery.

A second and very important component of a battery charge/discharge system is a way to control the physical connection of the PSB to the battery. This is important for a couple of reasons: to avoid sparks when connecting the battery and the ability to quickly disconnect from the battery for safety reasons. A contactor, relay or switch are the typical choices for this function. If going for a contactor style connection, we recommend using a hermetically sealed DC contactor. These have sealed contactors surrounded by an inert gas which allows the user to open or close the contactor while under load. If a traditional contactor is closed or opened under load the resulting arc will typically weld the contacts closed. Therefore to avoid replacing your contactor after each test, make sure the one you choose is rated for the DC voltage and current you plan to have present during your test.

Monitoring

The next category of critical equipment fills the need to monitor the battery and equipment during testing to ensure everything is operating properly. The variables which need to be measured are: battery polarity, battery temperature, voltage and current to/from the battery. Of these, battery polarity is the most important variable from the very beginning. If a battery is connected directly to the input terminals of a PSB the device can be instantly damaged. This is why the polarity check is so important. The battery test system needs to be able to check the polarity of the attached battery and prevent the connection to the PSB if the polarity is reversed. Later, in the safety section, we will discuss a disconnect relay or contactor between the battery and the PSB. Figure 1 shows the placement polarity checker and the safety contactor. In order to enable the safety contactor, the polarity checker must give a signal that the polarity is correct. This will ensure an operator cannot connect a battery to the PSB unless the polarity is correct.

Battery temperature should also be monitored to ensure the battery is operating correctly and not heating up due to some problem. The battery manufacturer will be able to provide safe and unsafe battery temperature ranges that can be used to set battery temperature alarms within your battery test system. Like battery temperature, battery charge current and voltage need to be watched closely to ensure proper operation during all tests. Both can be easily monitored from the PSB, where you can also program limit and over protections to ensure the power supply will monitor these values for normal ranges and immediately shut off the power supply output if any variable gets out of control.

Figure 1

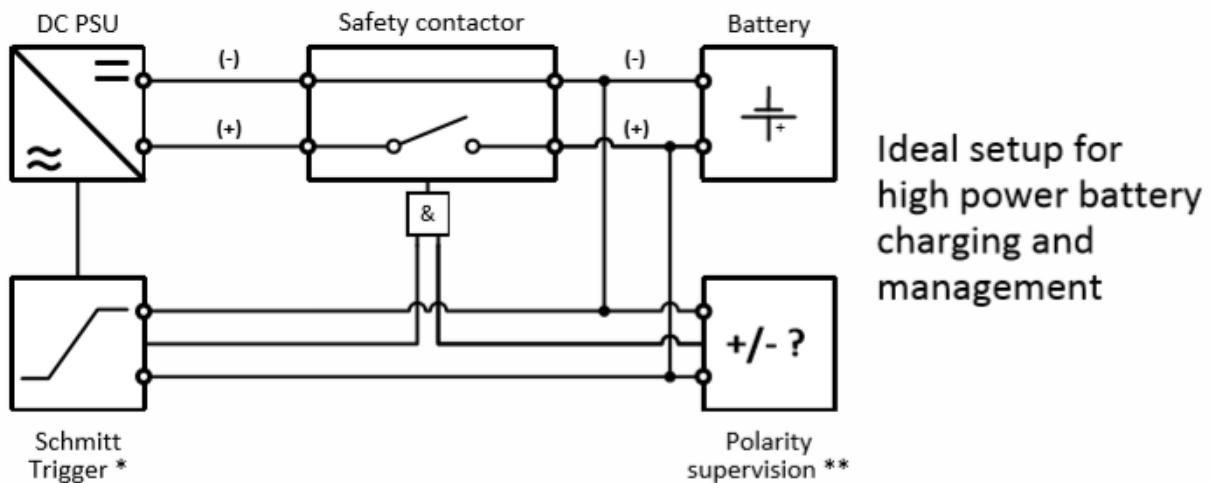

* Voltage level supervision circuit to set the PSU's output voltage to the battery voltage prior to enable the safety contactor

** Supervises correct polarity of the battery connection and enables the safety contactor

Safety

While all variables being monitored contribute to the safe testing of a battery using a bidirectional programmable DC power supply, there is one component that is essential for the safety of the operator and the equipment. That component is a DC contactor or relay that can isolate the battery from the rest of the test system. This relay, from the beginning of the test acts like a gatekeeper from the battery to the power supply. By using the polarity check to enable the contactor to close ensures the battery will not damage the power supply through a spike in negative voltage. The second important feature of the relay or contactor is to disconnect the battery from the PSB if a problem occurs, such as an overtemperature condition on the battery under test. The protection features for the PSB can send a signal to open the contactor in approximately 10 μ s to ensure the PSB and battery are protected from each other.

Optimizing the Battery Connection

One last important consideration for a battery test system using a PSB bidirectional DC power supply is the process of connecting the battery to the power supply. To do this properly you need to verify the polarity of the battery connection is correct and match PSB voltage to the battery terminal voltage. Figures 2 and 3 show these two configurations with the note “sparks when connecting.” If there is a difference in voltage potential of more than 1-200mV, a spark will occur when connecting the battery to the PSB. Batteries want to discharge into something and when they are connected to the PSB they will discharge into the PSB which charges the input capacitors. That quick burst of energy results in sparking and can damage the battery terminals. This can also damage the contacts of a contactor or relay connected between the PSB and battery. Similarly, when the battery is connected with reverse polarity, you will get sparks when connecting the battery. In addition, the PSB will most likely be damaged as it cannot protect itself from a negative voltage on its output terminals.

Figure 2

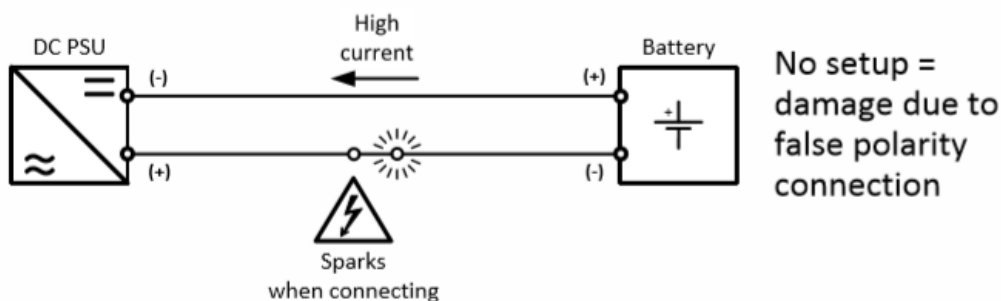
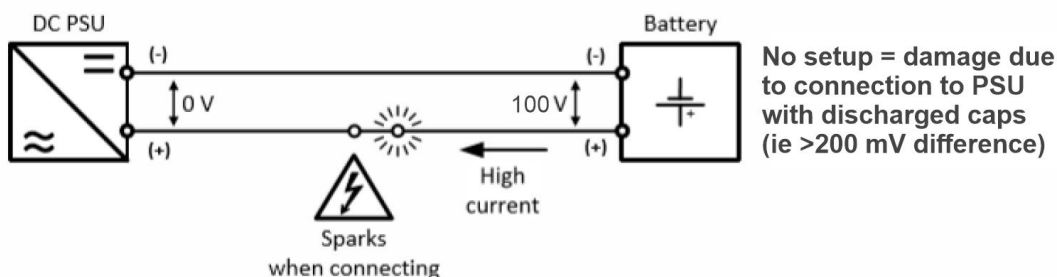

Figure 3



Conclusion

The most important thing to remember is to plan out your test procedure and setup before attempting to use a programmable DC power supply for battery testing. A simplified approach may work for some, but most will need to protect their battery under test, the DC power supply and of course the operator. Planning with 3 elements in mind: control, monitoring and safety will give you the best chance at developing a complete and safe battery test solution. Using the EA PSB will further simplify a system by being able to charge and discharge from one unit, avoiding the need to move the battery around or utilizing multiple relays to switch between a power supply and load going to the battery. To get more information on the PSB series or to determine your ROI on the PSB series, please visit: <https://www.elektroautomatik.us>, email us at sales@elektroautomatik.com or call 858-836-1300.

Zeke Pietsch

Sr. Applications Support Engineer

EA Elektro-Automatik

858-836-1300